



praxedo

Leader SaaS de la
gestion d'interventions

15 ans d'expertise en gestion des interventions



**Application
SaaS**



**Techniciens
connectés**



Praxedo, c'est...

- 4** Une activité en forte croissance
- 5** +900 clients, +33.000 utilisateurs, +80.000 interventions/jour
- 6** Une présence reconnue à l'international
- 7** Une solution autonome ou connectée au S.I. du client
- 8** Une valeur ajoutée fonctionne sur l'ensemble du cycle d'intervention
- 10** Une position de leader SaaS reconnue
- 11** Une connaissance approfondie des enjeux « métier » de nos clients
- 12** Un hébergement sécurisé





Une activité en forte croissance

- +20% de croissance/an du CA
- Un des 500 Champions de la Croissance



- Croissance du nombre de collaborateurs depuis 2018

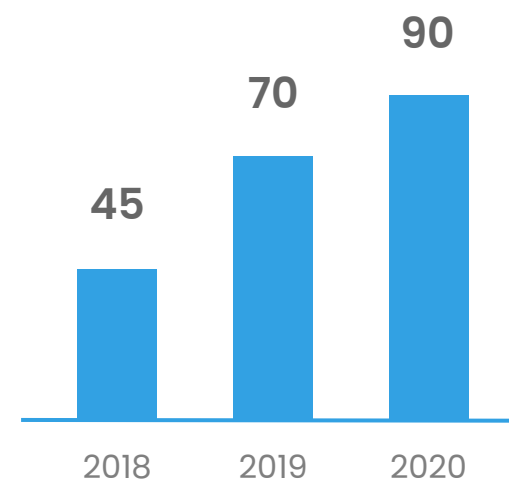



+900 clients, +40.000 utilisateurs, +70.000 interventions/jour

Des clients de toutes tailles dans plus de 50 secteurs d'activités

Telecom



Energy & Utilities



Facility Management & Home Repair



Retail



Public Works



Bank & Security





Praxedo à l'international



AUJOURD'HUI



France



Belgique



Luxembourg



Allemagne



Autriche



Suisse



Espagne



Portugal



Canada



UK



Une solution autonome ou connectée au S.I. du client

SI/ERP du client



Salesforce, Sage, SAP, Cegid,
Microsoft Dynamics AX / NAV / CRM,
SugarCRM, EBP, Divalto...

Interface WEB



Accessible via une simple
connexion web

Interface Mobile



Utilisable off-line/on-line selon la
disponibilité du réseau mobile



Des fonctionnalités sur l'ensemble du cycle de l'intervention



Planification intelligente



Suivi des activités et géolocalisation



Cockpit : indicateurs d'activité temps réel

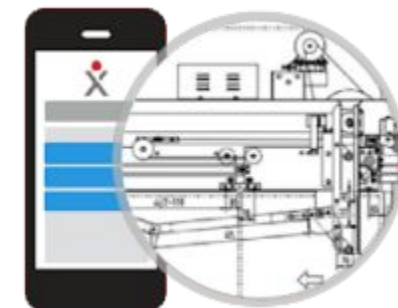
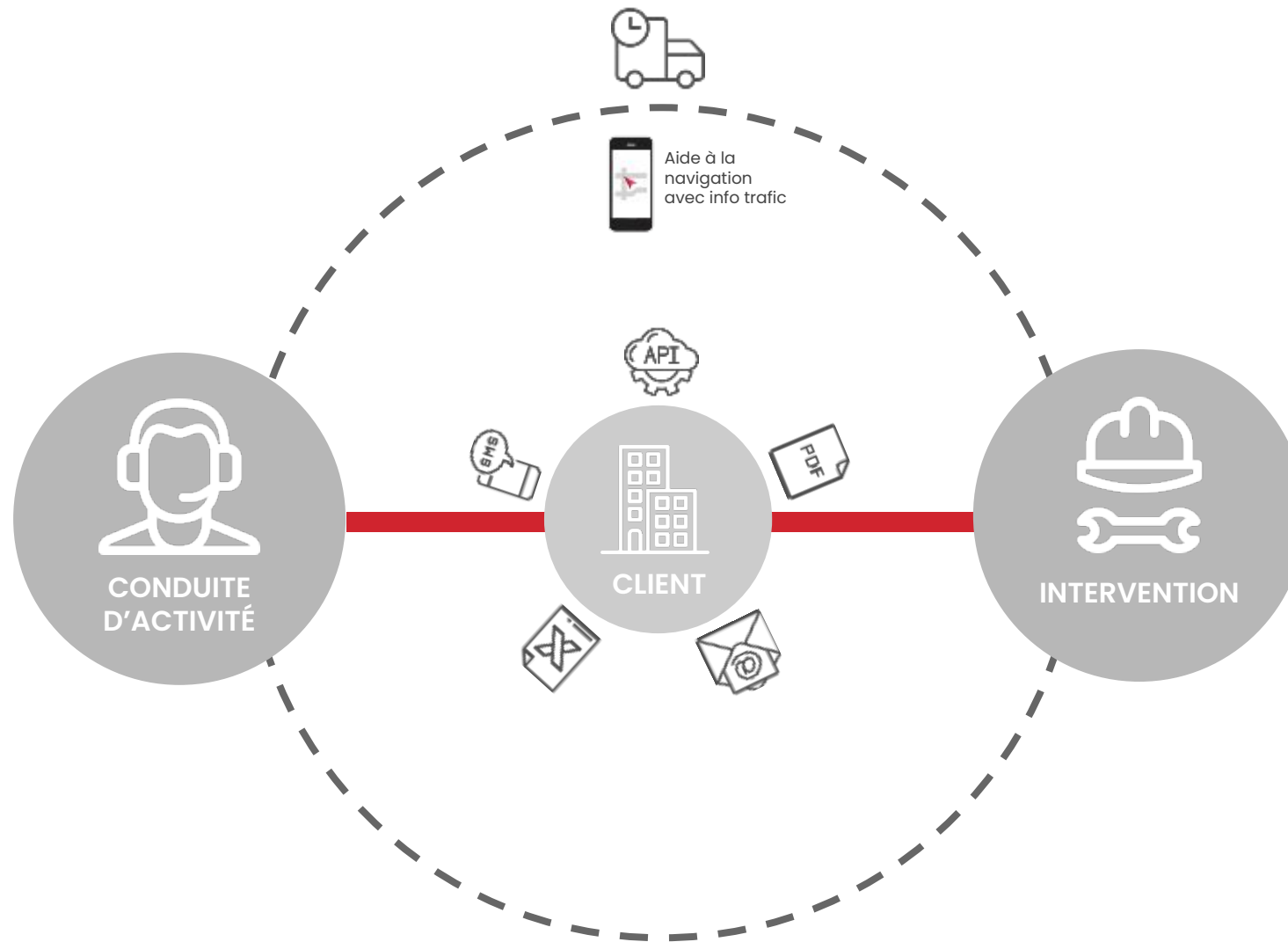

- Formulaires riches
- Gestion des stocks
- Saisie des temps
- Gestion documentaire
- Tableau blanc partagé





Une valeur ajoutée sur l'ensemble du cycle de l'intervention



Optimisez le temps de charge de vos techniciens



Optimisez la planification des tournées



Pilotez votre activité et analysez vos résultats

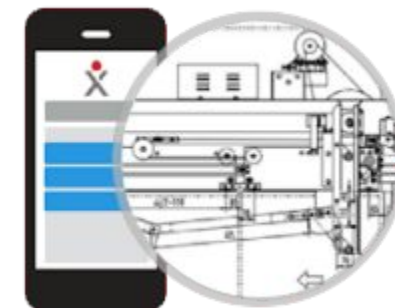
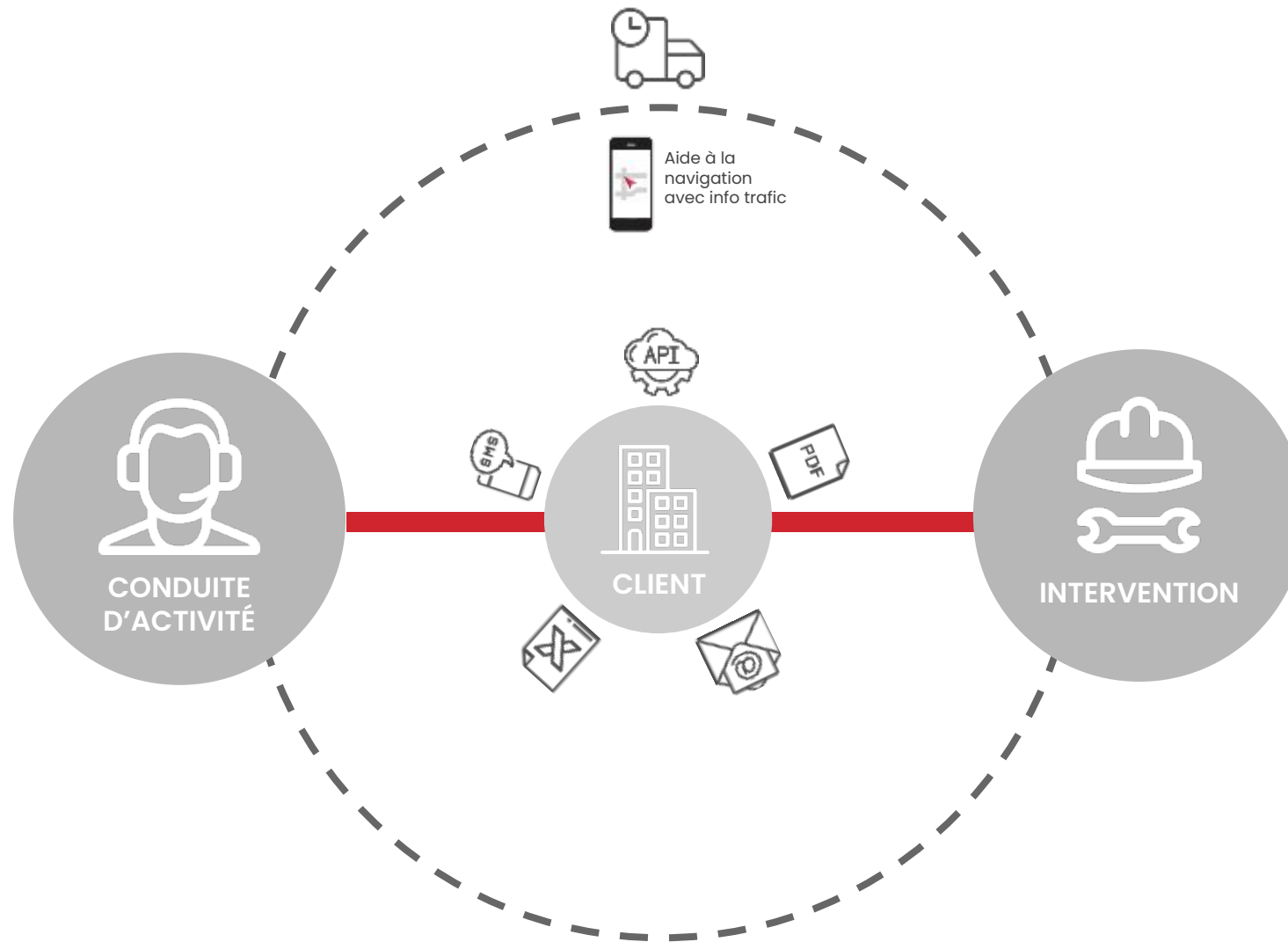

Équipez vos techniciens sur le terrain et sécuriser la collecte des informations.

Améliorez le suivi de votre activité et la qualité de votre service.





Une position de leader SaaS reconnue

Gartner[®]

 Magic Quadrant

Pour la 4ème fois consécutive dans le Magic Quadrant de Gartner.

Force : capacité à sécuriser les projets + délais d'implémentation les plus rapides du marché





Une connaissance approfondie des enjeux « métier » de nos clients

- Praxedo a développé une véritable expertise métier
- Praxedo publie régulièrement les meilleures pratiques du Field Service Management

Guides pratiques

www.praxedo.com/ressources

“Choisir une solution de gestion d'interventions : les 10 questions à se poser”



Livres blancs

www.praxedo.com/ressources

“Frigoristes & Maintenance : quelles solutions pour quelles problématiques ?”



+200 articles de blog

www.praxedo.com/blog





Hébergement / Disponibilité

- Solution multi-tenant, hébergée sur des serveurs dédiés chez OVH, certifié ISO27001 (France pour les clients européens / Québec pour les clients Nord-américains)
- 2 infrastructures identiques (nominales et secours) dans 2 datacenters différents
- Sauvegarde des données sur 3 sites géographiques distincts
- Renouvellement tous les 18 mois
- Taux de disponibilité observé > 99,9%
- Stockage illimité des données (en volume et en durée)



praxedo

**Merci
pour votre attention !**